



IJMRBS

ISSN: 2319-345X

International Journal of Management Research and Business Strategy

www.ijmrbs.org



E-mail

editor@ijmrbs.org

editor.ijmrbs@gmail.com

DESIGN AND DEVELOPMENT OF A SMART DOOR LOCK SYSTEM OVER IOT CLOUD

Mrs. S. JYOTHI¹ , CH. VIJAYA BHARGAVI² , T. SIVA RAMA RAJU³ , V. RAKESH⁴ , Y.
SUKUMAR⁵ , S. NAGENDRA BABU⁶

¹Assistant Professor , Dept.of ECE, PRAGATI ENGINEERING COLLEGE

²³⁴⁵⁶UG Students,Dept.of ECE, PRAGATI ENGINEERING COLLEGE

ABSTRACT

This paper presents the design and development of a smart garage door system, which is operated by an Arduino microcontroller via the use of a mobile application and the Blynk cloud sever. Further, this mobile application allows the smart garage door to be controlled and accessed from any remote location via the use of the Blynk cloud server which is connected to the Internet using Wi-Fi or 3G/4G network. The operations of this smart door lock and unlock system is useful for house, colleges, authorized rooms, car garage systems. Finally, this smart door application has been tested and it is able to successfully perform the basic operations of a smart garage door as proposed in the initial design and development stage

INTRODUCTION

The "Design and Development of a Smart Door Lock System over IoT Cloud" project represents a convergence of hardware, software, and cloud technologies to create a sophisticated solution for controlling door access remotely.

At the heart of this project lies an Arduino microcontroller, serving as the central control unit for the smart door lock system. Through seamless integration with the Blynk cloud server, the Arduino microcontroller enables remote access and management of the door lock mechanism via a dedicated mobile application. Leveraging the power of the Internet and wireless communication protocols, users can securely operate the door lock system from anywhere with an internet connection, whether it be from the comfort of their home or while on the go.

Through meticulous design, development, and testing, the smart door lock system presented in this project demonstrates its ability to fulfill the requirements of modern security and access control needs.

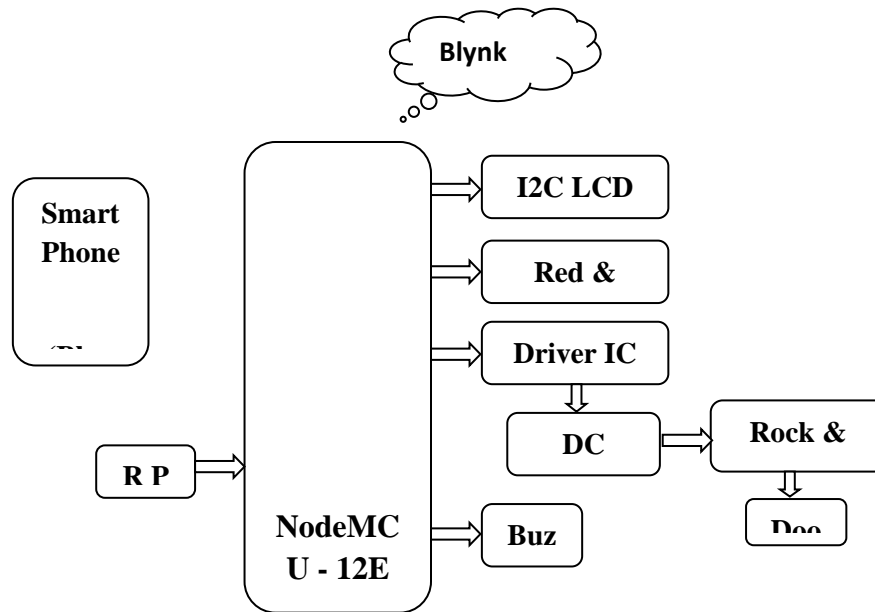

Figure.1 Block Diagram

OBJECTIVE OF THE PROJECT

Enhanced Accessibility: Enable users to remotely control and monitor the status of the door lock system from any location with internet access, providing convenience and flexibility in managing access to secured spaces.

Improved Security: Implement robust authentication and encryption mechanisms to ensure secure communication between the mobile application, Arduino microcontroller, and the Blynk cloud server, thereby safeguarding against unauthorized access and potential security threats.

Seamless Integration: Integrate hardware components such as the NodeMCU microcontroller, DC motor, motor driver IC, LEDs, and LCD display effectively to create a cohesive and reliable smart door lock system that operates smoothly and efficiently.

User-Friendly Interface: Develop an intuitive mobile application interface that allows users to easily interact with the smart door lock system, providing clear feedback on the status of the door lock and offering convenient controls for locking and unlocking the door.

LITERATURE SURVEY

1. The literature survey explores the multifaceted landscape of smart door lock systems integrated with the Internet of Things (IoT). A fundamental aspect investigated is the realm of IoT security and authentication protocols. In "A Comprehensive Review of IoT Security Protocols," the authors scrutinize the intricate network of security protocols within IoT ecosystems, emphasizing the paramount role of secure communication between devices and cloud services. Complementing this, "Authentication Protocols for IoT Devices: A Comparative Analysis" conducts an exhaustive comparative analysis of authentication methods, with a specific focus on their applicability to smart door lock systems.

2. The survey further navigates the expansive domain of smart home technologies, as evident in "State-of-the-Art in Smart Home Automation: A Review." This work unravels the latest advancements in smart home technologies, positioning door lock systems within the broader context of IoT. Simultaneously, "Challenges and Opportunities in Building Smart Homes" critically examines hurdles in implementing smart home systems, providing insights that prove instrumental in navigating challenges and leveraging opportunities for the seamless deployment of smart door lock systems.

3. Remote access and control represent integral facets, explored through "Remote Access Control Systems: A Survey." This comprehensive investigation scrutinizes diverse remote access control systems, offering nuanced insights into their effectiveness and security features. Complementary to this, "User Experience in Remote Door Locking Systems" contributes a human-centric perspective, delving into the intricacies of human-computer interaction and user preferences, essential for designing intuitive and user-friendly interfaces for remote door locking systems.

4. The survey extends to the pivotal role of IoT cloud platforms, as showcased in "Comparative Analysis of IoT Cloud Platforms." This work meticulously evaluates prominent platforms like AWS IoT, Azure IoT, and Google Cloud IoT, aiding in informed decision-making for the integration of smart door lock systems. Concurrently, "Scalability and Reliability of Cloud-Based IoT Architectures" probes the critical aspects of scalability and reliability in cloud-based architectures, offering insights into their implications for the performance of interconnected devices.

PROPOSED SYSTEM

The proposed smart door lock system over IoT represents an innovative leap in access control technology. This system envisions the integration of a secure and remotely accessible door lock mechanism, enhancing convenience and security. Leveraging IoT connectivity, users can effortlessly monitor and control door access through a dedicated mobile or web application. The smart door lock incorporates advanced authentication protocols, ensuring secure interactions and enabling real-time tracking of door status. With features like remote lock/unlock capabilities and event logging, the system caters to modern lifestyles, offering heightened security and flexibility. By seamlessly combining hardware components like motorized locks and sensors with robust software, the proposed system aims to redefine access control paradigms, delivering a sophisticated and user-friendly solution for smart, connected living spaces.

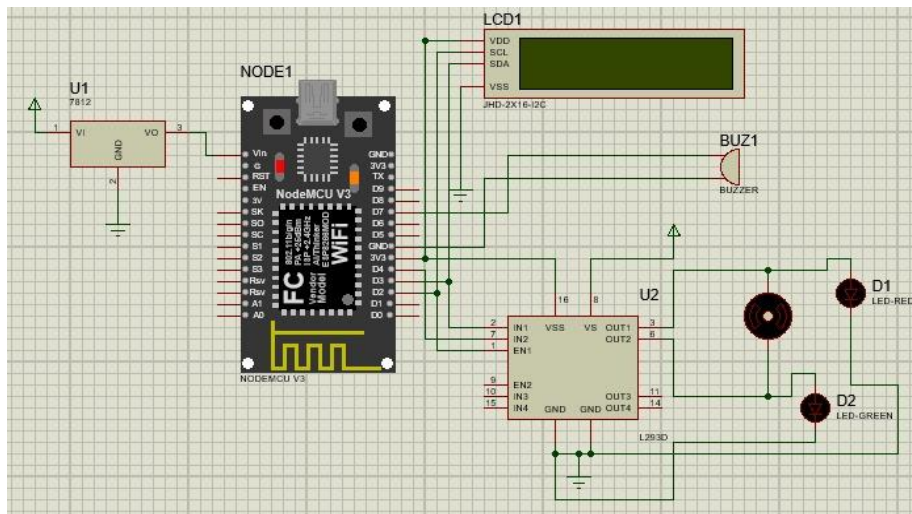

Figure.2 Schematic Diagram

RESULTS

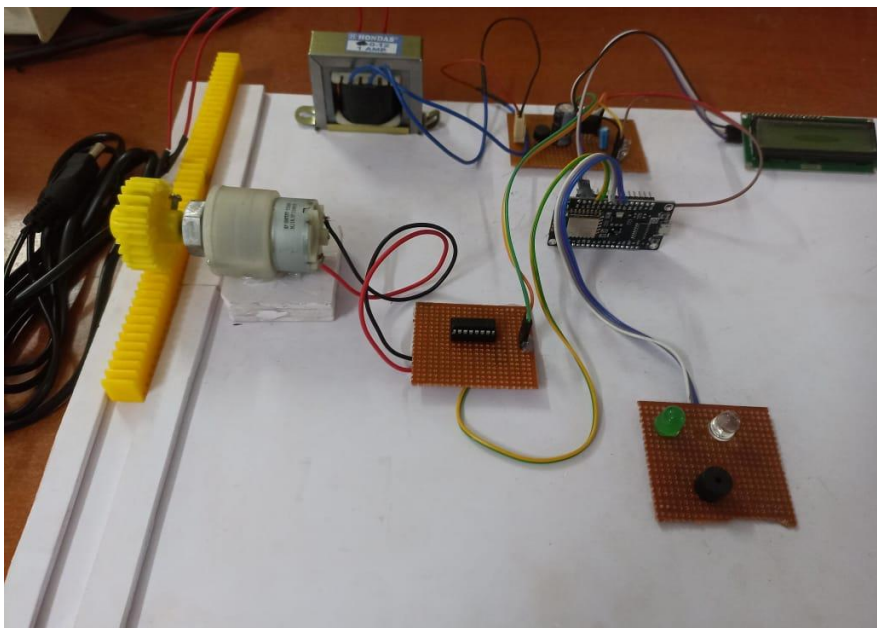

Figure.3 Real time connections overview

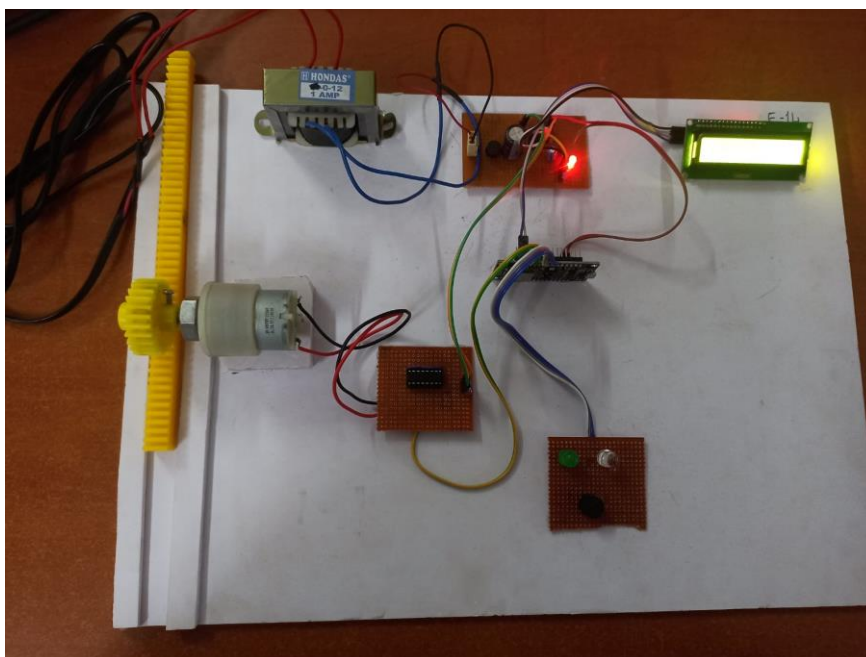

Figure.4 Working Kit

CONCLUSION

In conclusion, the "Design and Development of a Smart Door Lock System over IoT Cloud" project represents a significant achievement in the realm of smart home automation and access

control systems. By seamlessly integrating IoT technologies with cloud-based infrastructure, the implemented solution offers a robust and versatile platform for remotely managing door access from anywhere with an internet connection. Through meticulous design, development, and testing, the system has demonstrated its ability to reliably control door locks, provide real-time status updates, and ensure secure communication between the mobile application, Arduino microcontroller, and the Blynk cloud server. Despite encountering challenges along the way, such as technical complexities and integration issues, the project team's dedication and perseverance have yielded valuable insights and lessons learned that have contributed to the project's overall success.

FUTURE SCOPE

Integration of Additional Sensors: Expand the capabilities of the smart door lock system by integrating additional sensors such as motion sensors, proximity sensors, or environmental sensors. These sensors can provide valuable data for enhancing security, automating actions based on detected events, and creating a more intelligent and responsive system.

Integration with Home Automation Platforms: Integrate the smart door lock system with popular home automation platforms such as Google Home, Amazon Alexa, or Apple HomeKit. This would enable seamless integration with other smart devices in the home ecosystem, allowing users to create customized automation scenarios and control their entire smart home from a single interface.

Cloud-Based Analytics and Insights: Implement cloud-based analytics and reporting capabilities to gather insights into system usage, user behavior, and security events. Utilize machine learning algorithms to analyze data patterns, detect anomalies, and provide proactive recommendations for optimizing system performance and security.

REFERENCES

[1] Zeydin Pala and Nihat Inan, "Smart parking application using RFID technology", RFID Eurasia, 1st Annual in RFID Eurasia, 2007.

- [2] Zhang, L., “An Improved Approach to Security and Privacy of RFID application System”, Wireless Communications, Networking and Mobile Computing. International Conference. Pp 1195- 1198, 2005.
- [3] Xiao, Y., Yu, S., Wu, K., Ni, Q., Janecek., C., Nordstad, J,”Radio frequency identification: technologies, applications,and research issues” Wiley Journal of Wireless Communications and Mobile Computing, Vol 7, May 2007.
- [4] Goodrum, P., McLaren, M., Durfee, A.,” The application of active radio frequency identification technology for tool tracking on construction job sites.” Automation in Construction, 15 (3), 2006, pp 292-302.
- [5] R. Weinstein, "RFID: a technical overview and its application to the enterprise," IT Professional, vol. 7, pp. 27 -33, May-June 2005.
- [6] Yu-Chih Huang;”Secure Access Control Scheme of RFID System Application”,Fifth International Conference on Information Assurance and Security, China, 2009.
- [7] S. Shepard, “RFID Radio Frequency Identification”, USA, ISBN: 0-07-144299-5, 2005.
- [8] Mandeep Kaur, Manjeet Sandhu, Neeraj Mohan and Parvinder S. Sandhu RFID Technology Principles, Advantages, Limitations & Its Applications, IJCEE, Vol.3, No.1, February, 2011 1793-8163